

ULS-60 Multi-Point Ultrasonic Level Controller

- ▶ Accurate and reliable level detection to 12 feet
- ▶ Dual relay channels for pump, valve and alarm automation
- ▶ Automatic temperature compensation over entire range
- ▶ Simple potentiometer calibration for all relay set points

These versatile, general purpose ultrasonic liquid level switches mount in the top of your tank and provide non-contact level detection from 6 inches to 12 feet. With two integral relays, you can control pumps, valves or alarm controls.

Specifications

Accuracy	±0.25% of span
Resolution	0.125"
Pulse Rate	3 per second
Beam Width	8-degree conical
Supply Voltage	120 VAC
Pressure	30 psi @ 77°F
Temperature	-40°F to +140°F (-40°C to +60°C)
Enclosure Rating	NEMA 4X (IP 65)
Enclosure Material	Polypropylene
Conduit Connection	0.5" NPT
Sensor Material	PVDF
CE Compliance	EN 50082-2 immunity EN 55011 emissions

Relays

Set Points	2 per relay
Relay Types	(2) SPDT
Relay Rating	250 VAC, 10A, 0.5 hp
Adjustments	Potentiometer
Relay Mode	Selectable NO or NC
Relay Latch	ON or OFF

How to Order

Specify by part number based on measurement range.

Range	Frequency	Dead Band	Mounting	Part Number	
				120 VAC	(18 - 30 VDC)
3.6" to 6'	83 kHz	3.6"	0.75" NPT	195132 ⚡	198732 ⚡
6" to 12'	50 kHz	6"	2" NPT	195130 ⚡	198730 ⚡

⚡ - Stock Items



Dimensions

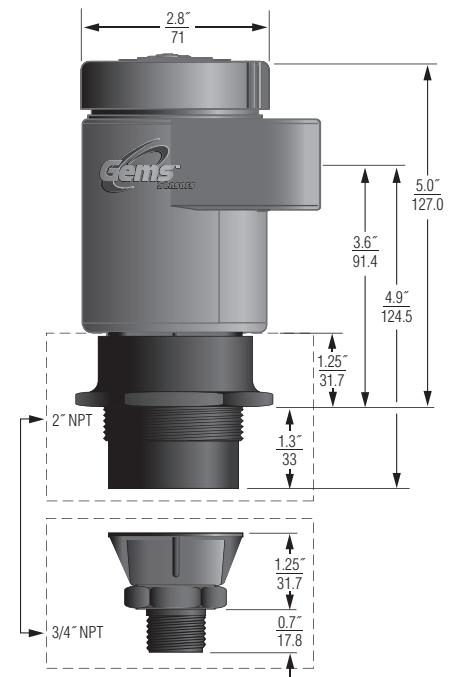

Typical Application

